

OptiSheath™ Advantage Sealed Terminal (UCA4-xx & UCA5-xx)

An Evolant® Solutions Product

Corning
Cable Systems

Description

The OptiSheath™ Advantage Terminal (UCA4-xx and UCA5-xx) is designed for the aerial, pole, pedestal or buried fiber access network. This innovative terminal provides sealed environmental protection and quick incremental connection of subscribers' drop cable. This unique design allows additional subscribers to be connected without opening the terminal, saving significant time and money.

Features / Benefits

- Provides a low-cost aerial or buried terminal optimized for optical access architectures
- OptiSheath Advantage Terminal is designed to install easily on strand, wall, pole, pedestal or below-grade in a handhole or manhole
- Blank adapters available for branch splicing of flat drop cables into terminal
- Appropriate number of pigtails in splice tray included with terminals
- Wall bracket (-W) includes UCAO-BK1 or pole bracket (-P) includes UCAO-POLE
- Designed and third-party tested to meet the requirements of Telcordia GR-771-CORE, Issue 1
- Terminal Fiber Management Capabilities include:
 - Up to 6 feet of slack storage
 - Maximum fiber cable capacity is 72 loose tube and 216 ribbon
 - Accommodates up to 3 splice trays (36 single fibers)
- Mass ribbon splicing available with ribbon tray (UCAO-ST-03) ordered separately, maximum 144 splices (3 trays)

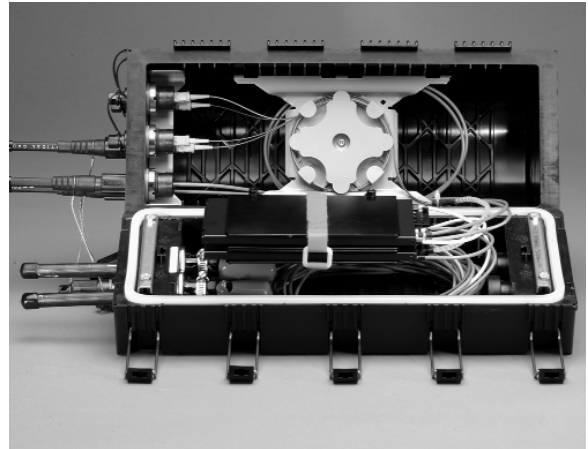

OptiSheath Advantage Sealed Terminal,
(open) | Photo SHD160

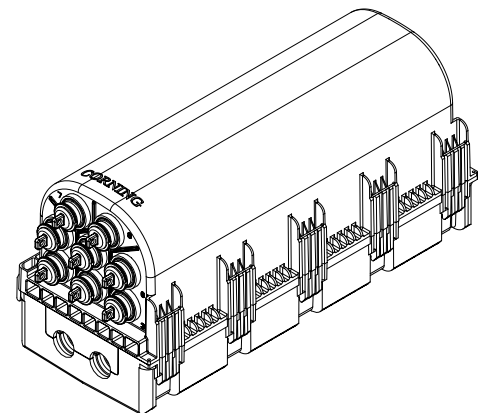

OptiSheath Advantage Sealed Terminal,
(closed) | Drawing ZA-2720

OptiSheath™ Advantage Sealed Terminal (UCA4-xx & UCA5-xx)

An Evolant® Solutions Product

Corning
Cable Systems

Specifications and Ordering Information

Dimensions (L x H x W) mm (in)	Weight kg (lb)
381 x 196 x 158.75 (15 x 7.72 x 6.25)	2.22 (6)

UCA - 6CP - -

1 **2** **3** **4**

1 Select number of adapters.

- 4 = Up to 8 OptiFit® Advantage Drop Cable Assembly or blank adapters (left end)
- 5 = More than 8 OptiFit Advantage Drop Cable Assembly or blank adapters (both ends)

Note: 1 to 8 positions left end with 9 to 16 on right end.

2 Select number of OptiFit Adapters.

- 02 = Two OptiFit Advantage Drop Cable Assembly adapters
- 04 = Four OptiFit Advantage Drop Cable Assembly adapters
- 06 = Six OptiFit Advantage Drop Cable Assembly adapters
- 08 = Eight OptiFit Advantage Drop Cable Assembly adapters
- 10 = 10 OptiFit Advantage Drop Cable Assembly adapters
- 12 = 12 OptiFit Advantage Drop Cable Assembly adapters
- 14 = 14 OptiFit Advantage Drop Cable Assembly adapters
- 16 = 16 OptiFit Advantage Drop Cable Assembly adapters

Note: 1 to 8 positions left end with 9 to 16 on right end.

Shaded boxes are optional part numbers

3 Select accessories.

- W = Includes specified number of OptiFit Advantage Drop Cable Assembly adapters, similar number of single-fiber pigtailed, one UCAO-ST-02, 12-position splice tray (2 trays with 14 and 16), 3-position tray stacker and wall bracket (Installation Instructions SRP-206-342)
- P = Includes specified number of OptiFit Advantage Drop Cable Assembly adapters, similar number of single fiber pigtailed, one UCAO-ST-02, 12-position splice tray (2 trays with 14 and 16), 3-position tray stacker and pole bracket (Installation Instructions SRP-206-342)
- CVR = CVR Upgrade Cover with specified number of OptiFit Advantage Drop Cable Assembly adapters, (pigtailed and additional tray sold separately) (Installation Instructions SRP-206-352)

4 Select number of blank adapters. (Optional)

- 2B = Includes all in W or P above with the addition of two blank adapters, two cable extension kits (KT-OPT-SHTH-FD) and splice trays
- 4B = Includes all in W or P above with the addition of four blank adapters, four cable extension kits (KT-OPT-SHTH-FD) and splice trays
- 6B = Includes all in W or P above with the addition of six blank adapters, six cable extension kits (KT-OPT-SHTH-FD) and splice trays

OptiSheath™ Advantage Sealed Terminal (UCA4-xx & UCA5-xx)

Corning
Cable Systems

An Evolant® Solutions Product

Accessories

Part Number	Description	Dimensions (L x H x W) mm (in)
UCAO-ST-02	Splice Tray with heat shrink protection slots (12 splices)	187 x 92 x 8 (7.4 x 3.6 x 0.33)
UCAO-ST-03	Splice Tray for 4 Mass fusion splices (48 splices)	187 x 92 x 8 (7.4 x 3.6 x 0.33)
UCAO-BK1	Wall-Mountable Bracket	
UCN8-KT-BND	Pole Strap	
UCN-KT-IT-TT	Band-It Tool for pole strap	
37R0044KITCOL-6	SC APC Pigtails, 900 µm (set of six), color 1.5 m	
37R0044KITCOL-4	SC APC Pigtails, 900 µm (set of four), color 1.5 m	
SCA-KT-VEL-12	Velcro straps 12" (20/pack)	
UCA4-KT-PLUG	Dummy plugs for cable entry ports (5/pack)	
UCA4-KT-EXP	Express cable strain relief hardware (10/pack)	
UCA4-KT-SR	Sealing ring gasket, silicone (10/pack)	
UCA-KT-AHD	Below Grade Optisheath™ Terminal aerial hanging bracket	
UCA-KT-FV-OP	Flash test valve adapter for OptiFit port (5/pack)	
UCA-KT-POLE	Below Grade Optisheath Terminal pole mount bracket	
UCAO-TP	UCA Sealing Tape (10/pack)	
UCA4-KT-SCREW	Metal screw for wedge and endcap (25/pack)	
UCN-GND-S20	Small 3M Bonding Clamp (Alligator) (20/pack)	
UCN-GNDCBL-20	6-Gauge 8" Ground Strap (20/pack)	
TKT-OTAP-CLN-001	OptiFit adapter cleaning kit (SRP-006-111)	
TKT-OPT-BG	Crimp tool and Heat Gun (SRP-009-043)	
TKT-OPT-JN	OptiFit Jam Nut tool kit for 1/4 socket wrench	
KT-OPT-SHTH-FD	OptiFit Cable extension kit for flat drop cable	
KT-OPT-ADPT	OptiFit adapter w/mounting hardware	
KT-OPT-SHTH-ADP	OptiFit adapter assembly for Optisheath Terminal	
KT-OPT-CONN-FD	Opti Fit SC Plug connector assembly, Flat Drop	

Contact Customer Service for pricing and availability.

OptiSheath™ Advantage Sealed Terminal (UCA4-xx & UCA5-xx)

An Evolant® Solutions Product

Corning
Cable Systems

Shipping Package Specifications

Dimensions (H x D x L) mm (in)	596.90 x 444.6 x 495.3 (23.5 x 17.5 x 19.5)
Weight kg (lb)	12.21(33) (four units)
Minimum Order Quantity	4 (four units per box)



CORNING
Discovering Beyond Imagination

Corning Cable Systems LLC • PO Box 489 • Hickory, NC 28603-0489 USA
800-743-2675 • FAX: 828-901-5973 • International: +1-828-901-5000 • www.corning.com/cablesystems

Corning Cable Systems reserves the right to improve, enhance and modify the features and specifications of Corning Cable Systems' products without prior notification. Evolant and OptiFit are registered trademarks of Corning Cable Systems Brands, Inc. OptiSheath is a trademark of Corning Cable Systems Brands, Inc. Discovering Beyond Imagination is a trademark of Corning Incorporated. All other trademarks are the properties of their respective owners. Corning Cable Systems is ISO 9001 certified. © 2004, 2006 Corning Cable Systems. All rights reserved. Published in the USA. EVO-460-EN / February 2006 / 2.5M