

## P3 750 Series Cables Product Descriptions

CommScope's P3® product line is the industry standard by which all coaxial trunk and distribution cables are measured. P3 has been proven robust and reliable by years of successful installations.

P3 750 is optimized for use in broadband distribution plants. Its low attenuation and inherent strength has made it an industry standard.

### **Standard P3 Construction**

A solid aluminum tube is precision swaged onto a high compression, micro-cellular foam dielectric core. The core contains a fully bonded copper clad center conductor.

<b>Aerial Installation</b>				
Part #	Description	Cable Weight	Shipping Wteight	Standard Length
<b>P3 750 CA</b>	Offers all of P3's standard construction features(w/out Jacket)	164 lbs/kft 244 kg/km	224 lbs/kft (333 kg/km)	2500 ft (762m)
<b>P3 750 JCA</b>	Offers all of QR's standard construction features	199 lbs/kft (296 kg/km)	260 lbs/kft (387 kg/km)	2500 ft (762m)
<b>P3 750 JCAM 188</b>	Has an integrated figure 8 galvanized solid steel messenger for self-supporting applications	292 lbs/kft (435 kg/km)	375 lbs/kft (558 kg/km)	2500 ft (762m)
<b>P3 750 JCAM 250 (Also Available)</b>		345 lbs/kft (513 kg/km)	429 lbs/kft (638 kg/km)	2500 ft (762m)
<b>Underground Installation</b>				
Part #	Description	Cable Weight	Shipping Wteight	Standard Length
<b>P3 750 JCASS</b>	Features CommScope's Migra-Heal floodant that seals jacket damage to inhibit corrosion	204 lbs/kft (304 kg/km)	264 lbs/kft (393 kg/km)	2500 ft (762m)
<b>P3 750 CableGuard</b>	offers an outer jacket with compartmentalized cells, providing excellent cut-through and crush resistance	256 lbs/kft (381 kg/km)	339 lbs/kft (504 kg/km)	2500 ft (762m)
<b>P3 750 JACASS</b>	Features CommScope's Migra-Heal floodant, a bonded, chrome-plated armor and twin polyethylene jackets for ultimate toughness	362 lbs/kft (539 kg/km)	445 lbs/kft (662 kg/km)	2500 ft (762m)

# P3 JCASS

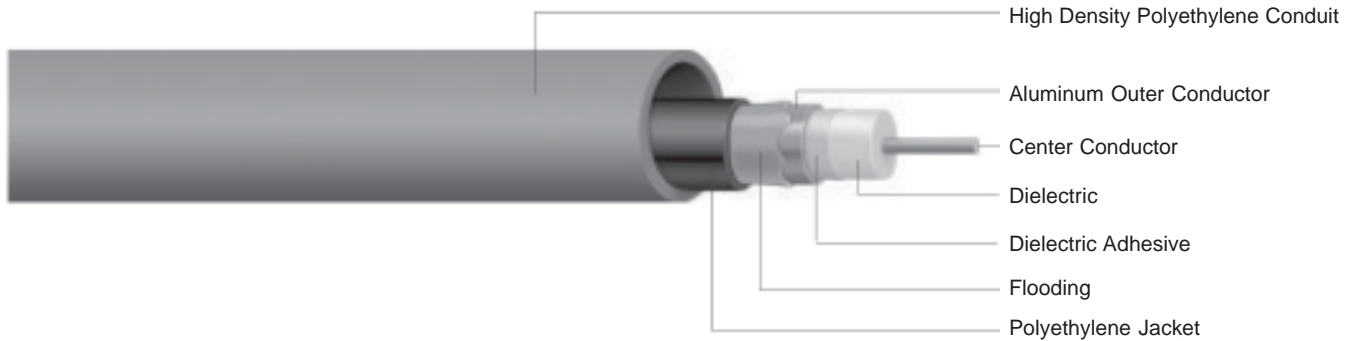

CommScope's P3® product line is the industry standard by which all coaxial trunk and distribution cables are measured. P3 has been proven robust and reliable by years of successful installations.

CommScope P3 offers low attenuation and inherent strength making it an industry standard.

CommScope offers several different sizes of P3 Cable-In-Conduit (500, 565, 625, 700, 750, 875 and 1000), each optimized for a specific use.

Size	Wall Thickness	Wall Rating	P3 500 JCASS			P3 565 JCASS			P3 625 JCASS		
			Nominal Length (ft)	Reel Size (FDT)(in)	Weight* lb/ft	Nominal Length (ft)	Reel Size (FDT)(in)	Weight* lb/ft	Nominal Length (ft)	Reel Size (FDT)(in)	Weight* lb/ft
1"	SDR 13.5	Medium	2,400	54x30x40	266	2,400	54x30x40	285	2,400	54x30x40	314
	SDR 11	Heavy	2,400	54x30x40	301	2,400	54x30x40	320	2,400	54x30x40	349
	SCH 40	X - Heavy	2,400	54x30x40	316	2,400	54x30x40	335	2,400	54x30x40	364
1 1/4"	SDR 13.5	Medium	2,400	63x30x40	362	2,400	63x30x40	381	2,400	63x30x40	410
	SCH 40	Heavy	2,400	63x30x40	392	2,400	63x30x40	411	2,400	63x30x40	440
	SDR 11	X - Heavy	2,400	63x30x40	417	2,400	63x30x40	436	2,400	63x30x40	465
1 1/2"	SDR 13.5	Medium	2,400	80x40x38	441	2,400	80x40x38	460	2,400	80x40x38	489
	SCH 40	Heavy	2,400	80x40x38	450	2,400	80x40x38	469	2,400	80x40x38	498
	SDR 11	X - Heavy	2,400	80x40x38	513	2,400	80x40x38	532	2,400	80x40x38	561
2"	SDR 13.5	Medium	2,400	90x42x40	569	2,400	90x42x40	588	2,400	90x42x40	617
	SCH 40	Heavy	2,400	90x42x40	629	2,400	90x42x40	648	2,400	90x42x40	677
	SDR 11	X - Heavy	2,400	90x42x40	737	2,400	90x42x40	756	2,400	90x42x40	785
			P3 700 JCASS			P3 750 JCASS			P3 875 JCASS		
1 1/4"	SDR 13.5	Medium	2,500	63x30x40	430	2,500	68x30x40	467	NA	NA	NA
	SCH 40	Heavy	2,500	63x30x40	460	2,500	68x30x40	497	NA	NA	NA
	SDR 11	X - Heavy	2,500	63x30x40	485	2,500	68x30x40	522	NA	NA	NA
1 1/2"	SDR 13.5	Medium	2,500	80x40x38	509	2,500	80x40x38	546	2,500	80x40x38	606
	SCH 40	Heavy	2,500	80x40x38	518	2,500	80x40x38	555	2,500	80x40x38	615
	SDR 11	X - Heavy	2,500	80x40x38	581	2,500	80x40x38	618	2,500	80x40x38	678
2"	SDR 13.5	Medium	2,500	90x42x40	637	2,500	90x42x40	674	2,500	90x42x40	734
	SCH 40	Heavy	2,500	90x42x40	697	2,500	90x42x40	734	2,500	90x42x40	794
	SDR 11	X - Heavy	2,500	90x42x40	805	2,500	90x42x40	842	2,500	90x42x40	902
			P3 1000 JCASS								
1 1/4"	SDR 13.5	Medium	NA	NA	NA						
	SCH 40	Heavy	NA	NA	NA						
	SDR 11	X - Heavy	NA	NA	NA						
1 1/2"	SDR 13.5	Medium	NA	NA	NA						
	SCH 40	Heavy	NA	NA	NA						
	SDR 11	X - Heavy	NA	NA	NA						
2"	SDR 13.5	Medium	2,400	90x42x40	843						
	SCH 40	Heavy	2,400	90x42x40	903						
	SDR 11	X - Heavy	2,400	90x42x40	1,011						

## Trunk & Distribution Cable Catalog Numbering Key

**P3 625 J CA M - 188**

P3  
 Size  
 (diameter over shield)  
 - 412 - 750  
 - 500 - 840  
 - 565 - 875  
 - 625  
 - 700  
 PE Jacket  
 Messenger  
 Copper Aluminum  
 Messenger Dia.

**Suffix**  
 - J - Jacketed  
 - CA - Copper Aluminum  
 - SS - Miagra-Heal Flooding Compound  
 - T - Trader  
 - M - Messenger  
 - EHS - Extra High Strength

### P3 Aerial Construction Configurations

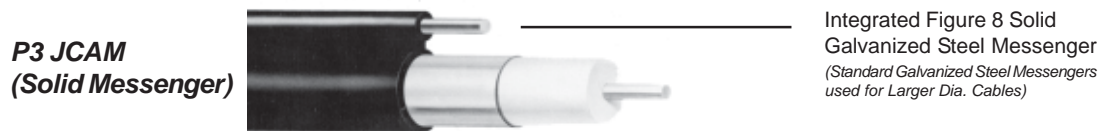
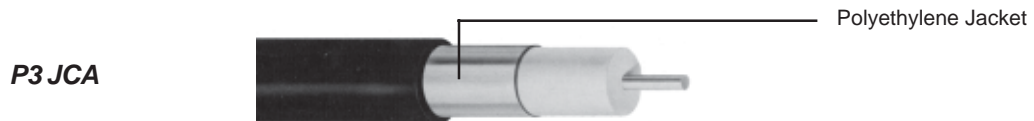
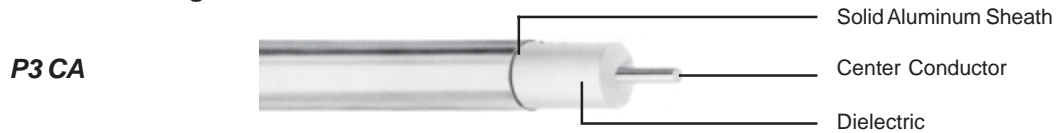

### P3 Underground Construction Configurations

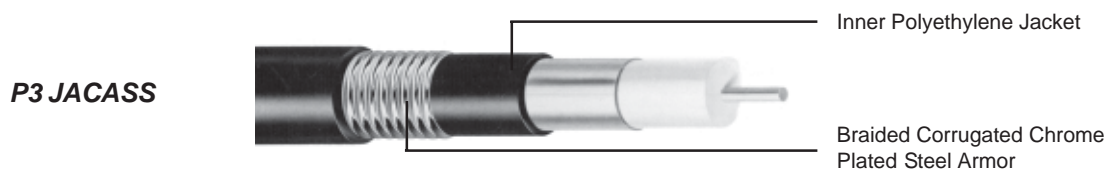
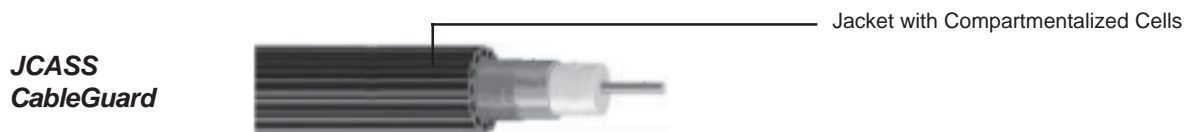
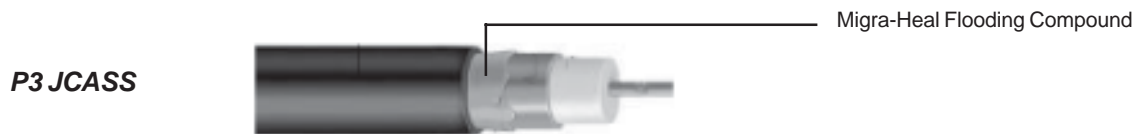

## P3 750 Series Cables Product Specifications

<b>Physical Dimensions</b>		
Component	Inches	mm
Nominal Center Conductor Diameter	0.167	4.24
Nominal Diameter Over Dielectric	0.680	17.27
Nominal Diameter Over Outer Conductor	0.750	19.05
Nominal Outer Conductor Thickness	0.035	0.89
<b>Jacketed Version</b>		
Nominal Diameter Over jacket	0.820	20.83
Nominal Jacket Wall Thickness	0.035	0.89
Nominal Dia. Over Flooded Jacket (JCASS)	0.830	21.08
Nominal Dia. Over CableGuard Jacket	1.055	26.80
<b>Messenger Version</b>		
Diameter of Steel Messenger	0.188	4.78
	0.250 <i>(stranded)</i>	6.35 <i>(stranded)</i>
<b>Armored Version</b>		
Nominal Diameter Over Corrugated Armor	0.900	22.86
Nominal Armor Thickness	0.010	0.25
Nominal Diameter Over Outer Jacket	0.980	24.59
Nominal Diameter of Outer Jacket	0.040	1.02

<b>Mechanical Characteristics</b>		
Minimum Bending Radius	Standard	Bonded
(No Jacket)	6.5 in / 16.5 cm	4.0 in / 10.2 cm
(Jacketed)	6.0 in / 15.2 cm	3.5 in / 8.9 cm
(Armored)	8.5 in / 21.6 cm	6.0 in / 15.2 cm
Maximum Pulling Tension	300 lbs	136 kg <sub>f</sub>
Minimum Breaking Strength of Messenger	(188) 3,900 lbs (250) 6,650 lbs	1,769 kg <sub>f</sub> 3,016 kg <sub>f</sub>

<b>Electrical Characteristics</b>		
Capacitance	15.3 ± 1.0 pf/ft	50 ± 3.0 nf/ft
Impedance	75 ± 2 ohms	
Velocity of Propagation	87%	

<b>Maximum D.C. Resistance @ 68°F (20°C)</b>		
Inner Conductor	0.57 ohms/1000ft	1.87 ohms/km
Outer Conductor	0.19 ohms/1000ft.	0.62 ohms/km
Loop	0.76 ohms/1000ft	2.49ohms/km

Frequency (Mhz)	<b>Attenuation @ 68°F (20°C)</b>			
	(dB/100 ft)		(dB/100 m)	
	Nom.	Max.	Nom.	Max.
5	0.10	0.11	0.33	0.36
30	0.25	0.26	0.82	0.85
45	0.31	0.33	1.02	1.08
50	0.33	0.35	1.08	1.15
55	0.35	0.37	1.15	1.21
83	0.42	0.46	1.38	1.51
108	0.48	0.52	1.57	1.71
150	0.57	0.62	1.87	2.03
181	0.66	0.68	2.17	2.23
193	0.68	0.71	2.23	2.33
211	0.71	0.74	2.33	2.43
220	0.72	0.76	2.36	2.49
250	0.77	0.81	2.53	2.66
270	0.80	0.84	2.62	2.76
300	0.85	0.89	2.79	2.92
325	0.88	0.93	2.89	3.05
350	0.91	0.97	2.99	3.18
375	0.96	1.01	3.15	3.31
400	0.99	1.05	3.25	3.45
425	1.02	1.08	3.35	3.54
450	1.06	1.12	3.48	3.67
500	1.11	1.18	3.64	3.87
550	1.19	1.24	3.90	4.07
600	1.23	1.31	4.04	4.30
750	1.38	1.48	4.53	4.86
865	1.49	1.61	4.89	5.28
1000	1.62	1.74	5.32	5.71